

Zakładka w kształcie słonia *Elephant bookmark*

Elephant bookmark
designed by Grzegorz Bubniak
diagrammed by Grzegorz Bubniak
e-mail: frydrych@skynet.com.pl

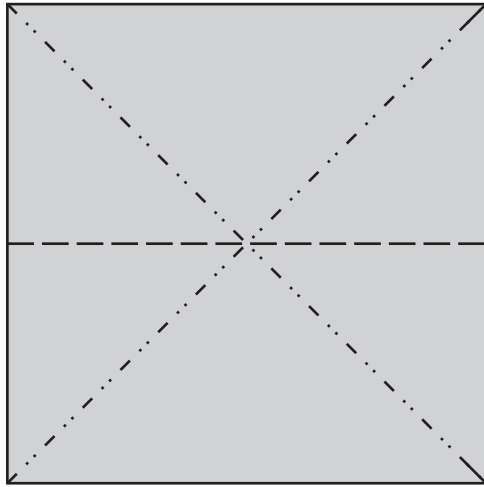

1.
Wykonaj zgięcia wed³ug linii.
Make creases as indicated.

2.
Zegnij do wewn¹trz.
Valley folds.

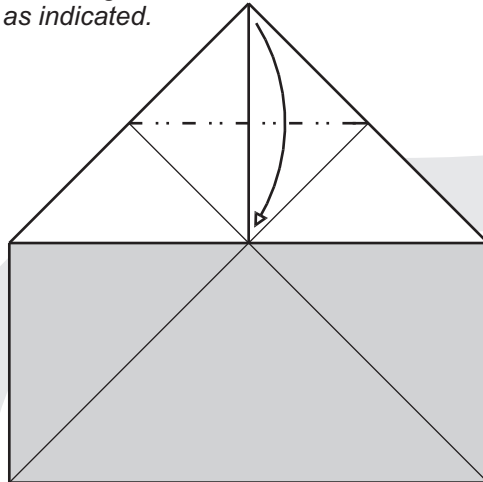
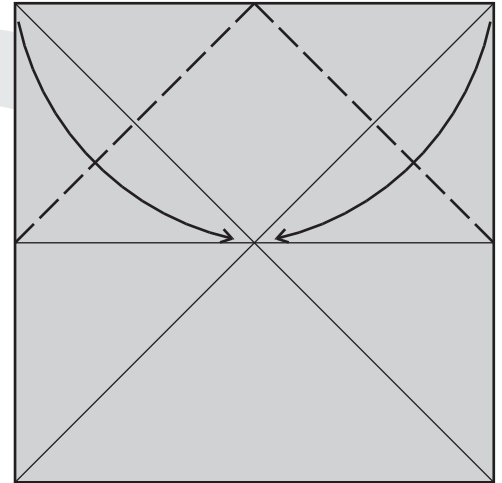

3.
Zegnij na zewn¹trz.
Mountain fold.

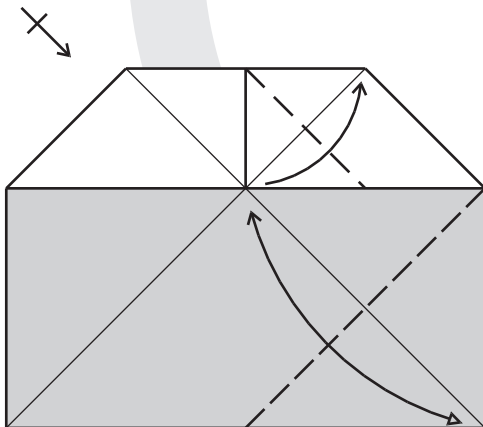

4.
U g³ory zegnij do wewn¹trz.
Na dole zegnij do wewn¹trz i rozegnij.
Powt³orz z lewej strony.
Valley fold at the top.
Valley fold and unfold at the bottom.
Repeat on the left.

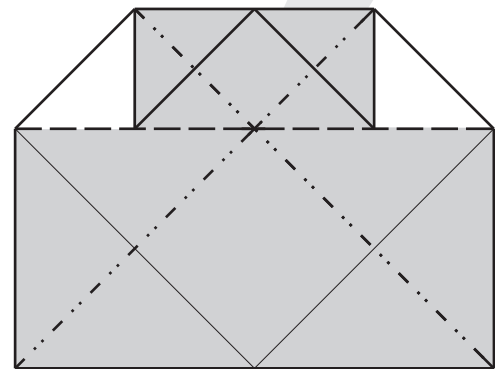

5.
Z³ó¿ jak bazê tr³ójk¹ta.
Fold as a waterbomb base.

12.
Zegnij ku do³owi,
Valley fold.

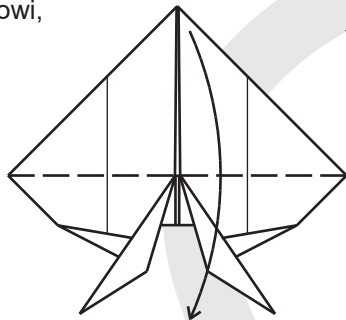

13.
Zegnij wed³ug zaznaczenia
chowaj¹c papier za tr¹bê.
Powtórz z lewej strony.
Swivel fold. Repeat on the left.

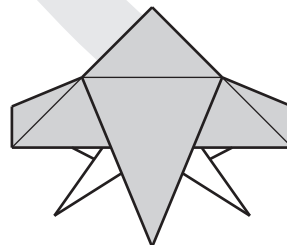

11.
Wykonaj zgiêcia wed³ug linii,
zaczni³ od podzia³u k¹ta na po³owê.
Powtórz kroki 9-10 z prawej strony
Make a swivel fold.
Start from bisecting the angle.
Repeat steps 9-10 on the right.

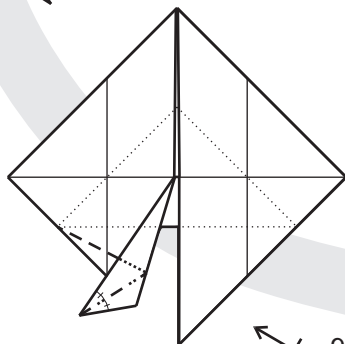

14.
Gotowe! Na³ó¿ zak³adkê na róg strony
wykorzystuj¹c tyl¹ kieszonekê.
Done! Use the pocket behind the model
to place it on the corner of a page.

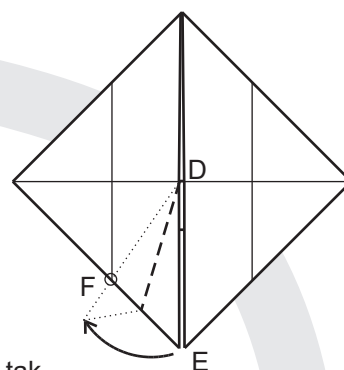

10.
Zegnij do wewn¹trz tak,
aby pocz¹tek zgiêcia le¿a³ w p. D,
a krawêdŸ DE przechodzi³a przez punktu F.
Make a valley fold so that it began in point D
and the edge DE was going through point F.

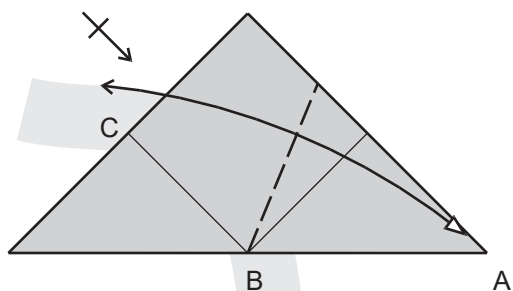

6.
Zegnij do wewn¹trz i rozegnij
krawêdŸ AB do zgiêcia BC.
Powtórz z lewej strony.
Valley fold, edge AB to crease BC.
Repeat on the left.

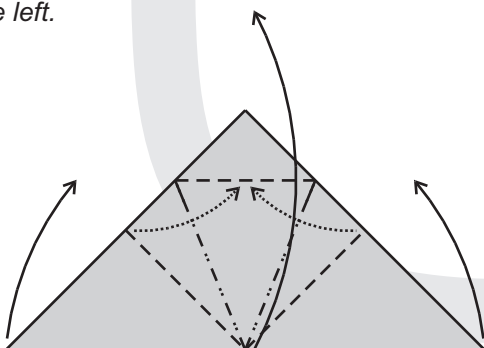

7.
Z³ó¿ model wed³ug zaznaczonych zgiêæ.
Fold according to the lines, like petal fold.

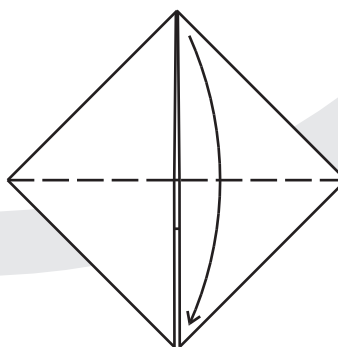

8.
Zegnij do wewn¹trz.
Valley fold.

9.
Z³ó¿ i roz³ó¿.
Powtórz z lewej strony
i roz³ó¿ do kroku 8.
Fold and unfold.
Repeat on the left
and unfold to step 8.

