

# Żółw morski Sea turtle

by A. F. Petlewski © 2004

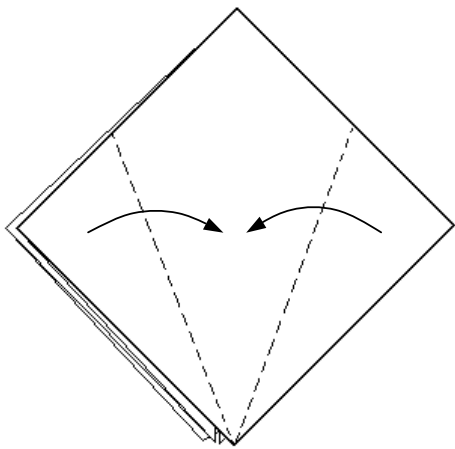

1. Zaczynij od figury 'podwójny kwadrat'.  
Begin with the base of 'double square'.

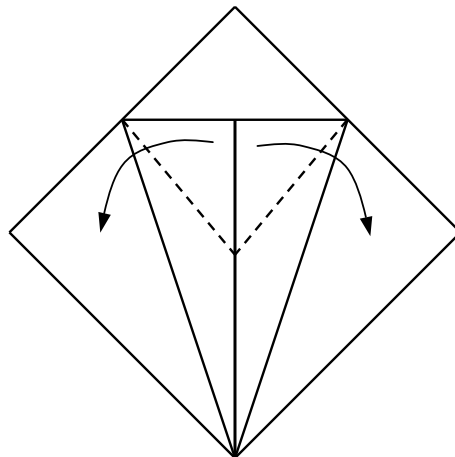

2.

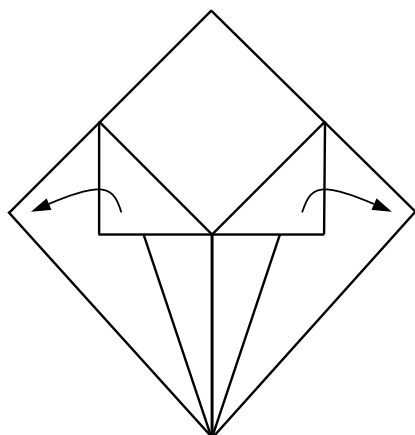

3. Rozprostuj.  
Open out.

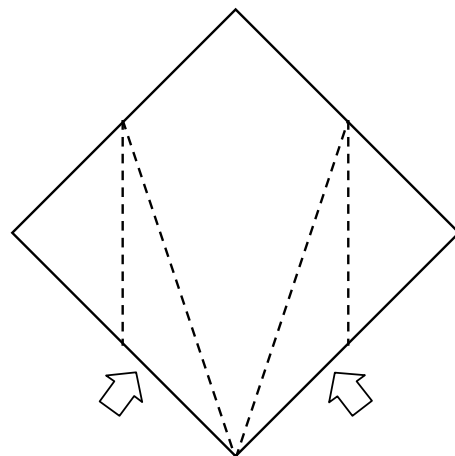

4. Zegnij do środka.  
Inside reverse fold.

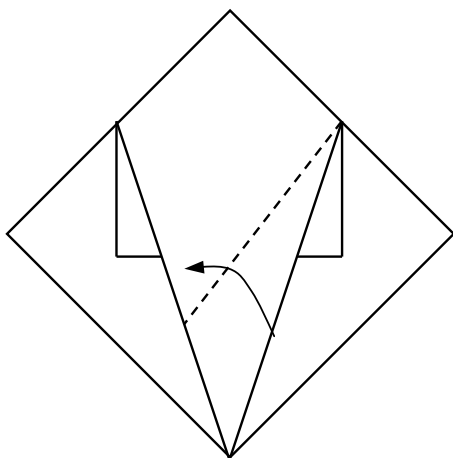

5.

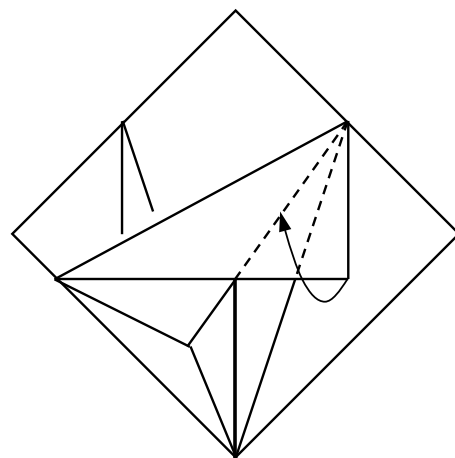

6. Rozłóż róg.  
Spread squash fold.

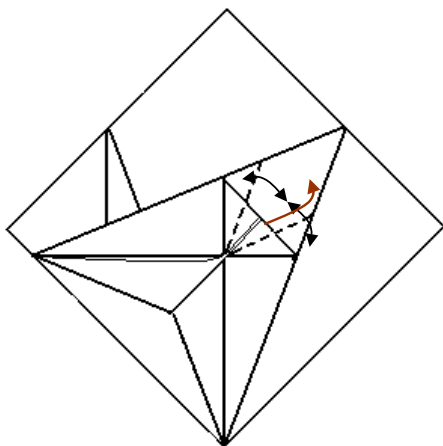

7. Utwórz zgięcia i zegnij do góry.  
Make creases. Fold up.

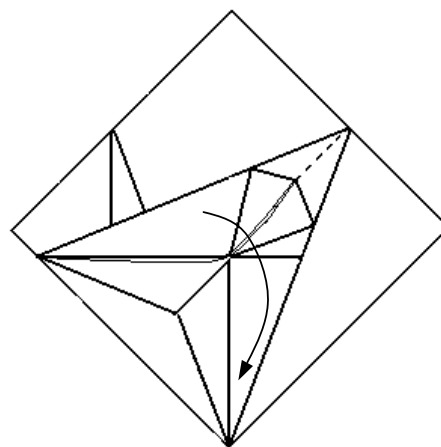

8. Złóż z powrotem.  
Fold back.

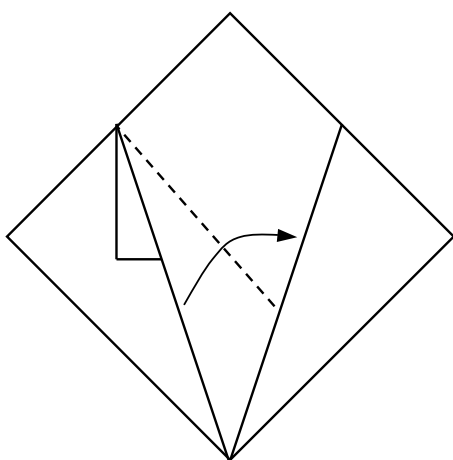

9. Powtórz krok 5 – 8 z lewej strony.  
Repeat 5 – 8 steps on the left side.

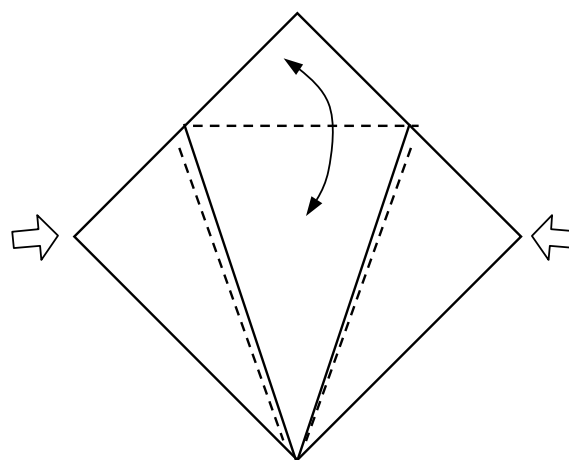

10. Utwórz zgięcie i wsuń odstające części do środka, tworząc z tyłu taką samą figurę jak z przodu.  
Inside reverse fold and make a crease.

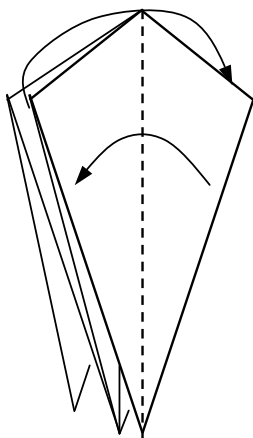

11. Odwróć prawą część i lewą z tyłu.  
Fold a single layer on the front & back.

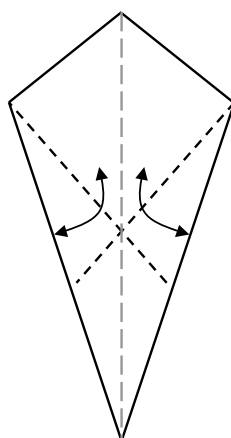

12. Utwórz zgięcia. Odwróć model.  
Make creases. Turn the model over.

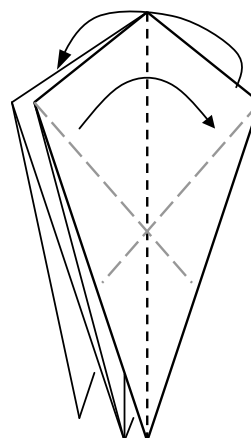

13. Utwórz zgięcia jak w kroku 12. i powróć do ułożenia modelu jak w kroku 11.  
Make creases (step 12) & fold a single layer on the front & back.

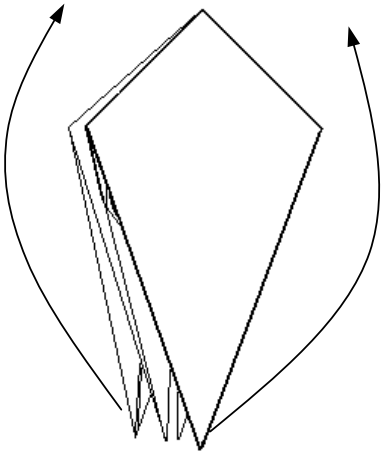

14. Rozprostuj ciągnąc tylną i przednią część.  
Open the model out.

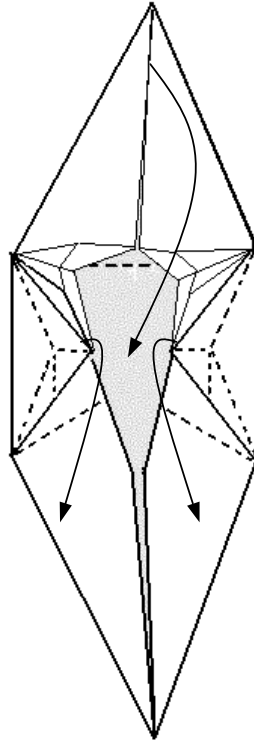

15. Złóż model zginając górną część. Boczne części złóż zgodnie z liniami.

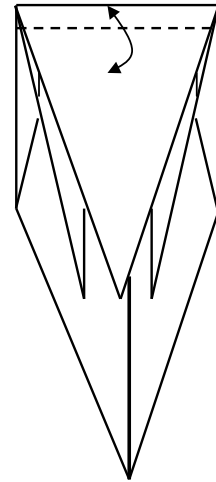

16. Złożony model. Zegnij i rozprostuj górną część.

Collapse the model along the existing creases to create figure like this ↑.

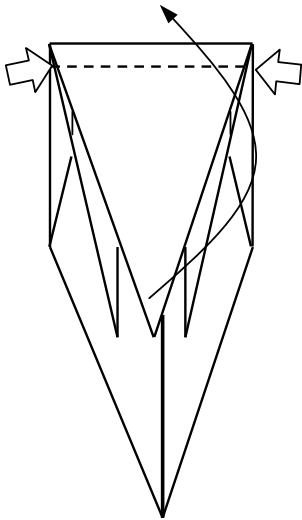

17. Zegnij trójkąt wpuszczając jego podstawę do środka modelu.  
Sink the base of this triangle inside.

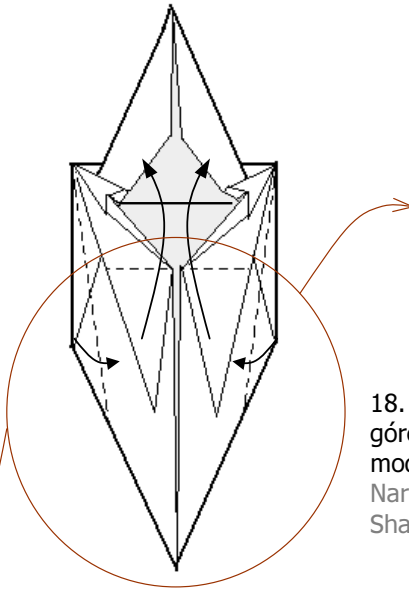

18. Zwęż model i odegnij łapy w górę. Uformuj dolną część modelu.  
Narrow sides of the model. Shape lower part.

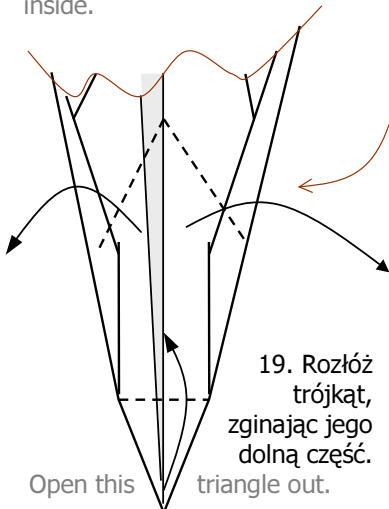

19. Rozłóż trójkąt, zginając jego dolną część.  
Open this triangle out.

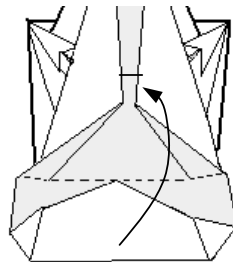

20. Złóż. Fold up.

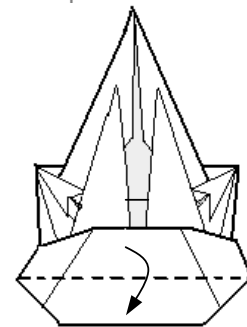

21.

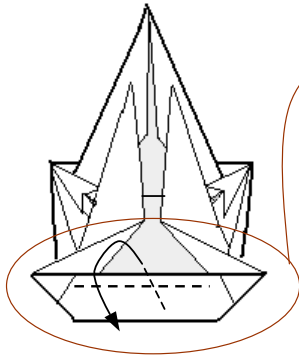

22. Wyciągnij ze środka.  
Pull out from the inside.

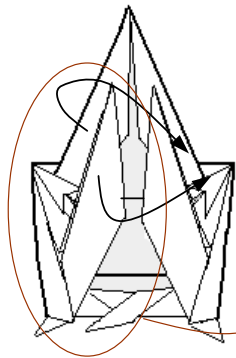

24. Rozprostuj lewą część.  
Open the left fin out.

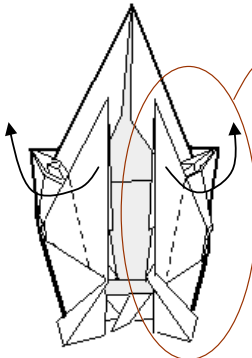

27. Zegnij.  
Fold.

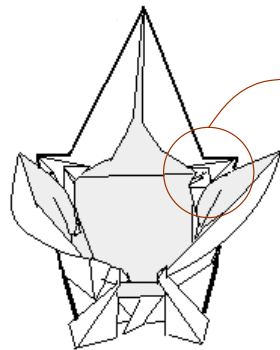

30. Wgnieć do środka rogi.  
Sink this part as shown.

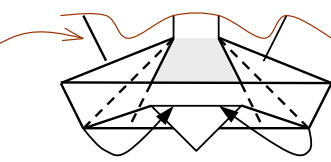

23. Uformuj łapy dolne i ogon.  
Złóż łapy w pół.  
Form paws & tail and then fold  
paws in half.

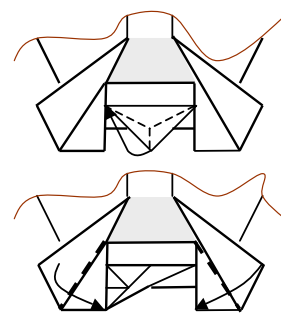

26. Rozprostuj łapy. Wgnieć do  
środku wystające części.  
Open paws. Sink inside along  
marked creases.

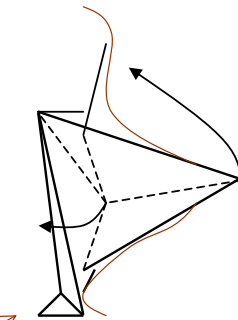

25. Zegnij na zewnątrz. Powtórz  
z drugiej strony.  
Collapse this layer along creases.  
Repeat on the right side.

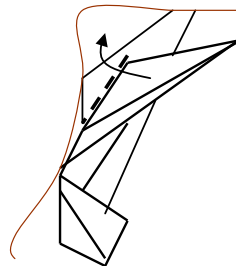
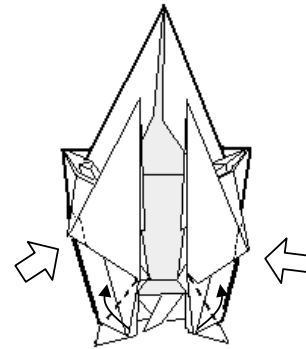

28. Rozwiń płetwę.  
Open the fin out.

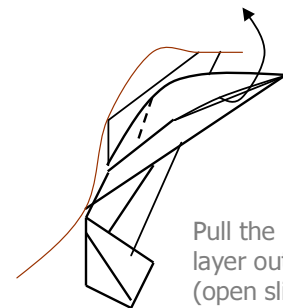

29. Wyciągnij ze środka górną  
część (otwierając lekko płetwę).  
Pull the inner  
layer out  
(open slightly  
the fin)

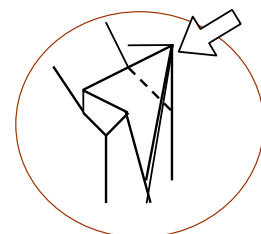
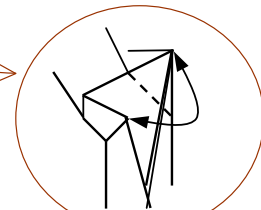

31. Wyprostuj ogon. Odwróć model.  
Shape tail. Turn the model over.

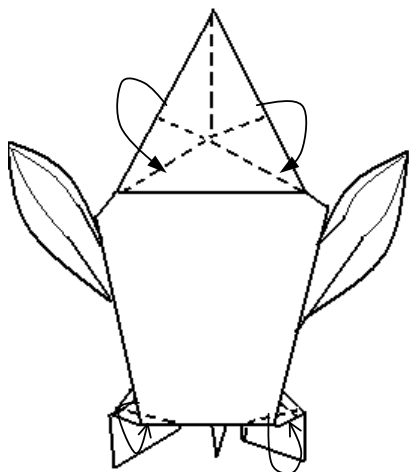

32. Zegnij do środka rogi przy łapach dolnych. Uformuj głowę.  
 'Rabbit ear' fold of head. Reverse fold near lower paws.

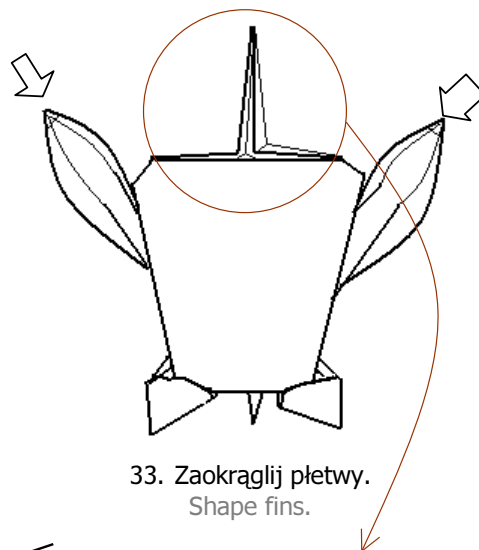

33. Zaokrąglj płetwy.  
 Shape fins.

34. Zgięcie w dół.  
 Outside reverse fold.

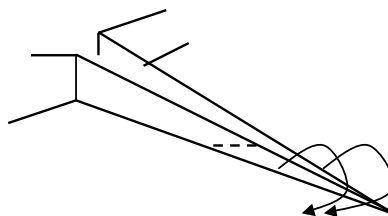

35. Wyjmij spod spodu.  
 Pull the paper out from underside.

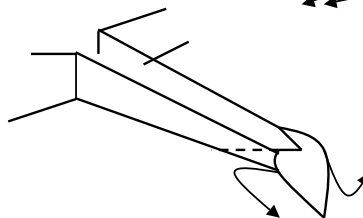

36. Zaokrąglj.  
 Shape head.

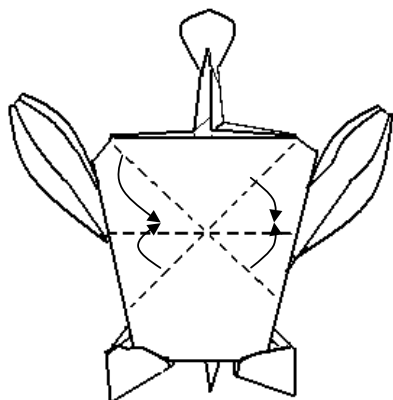
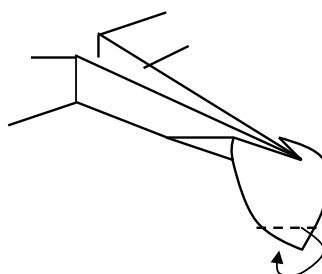

37. Uwypuklij pancierz.  
 Shape the shell.

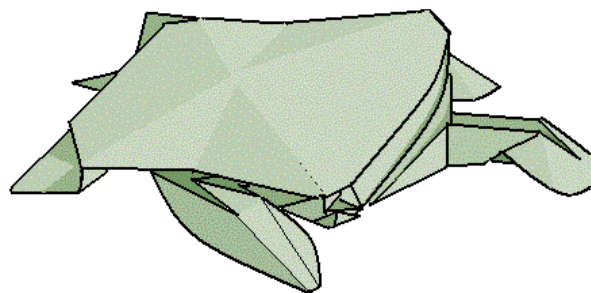

38. Skończony żółw.  
 Finished turtle.